

- Class B insulation approved as standard
- Flat pack 10.2mm low profile
- Flux tight or fully sealed versions available
- TV-5 rating
- UL/CSA/TUV recognised

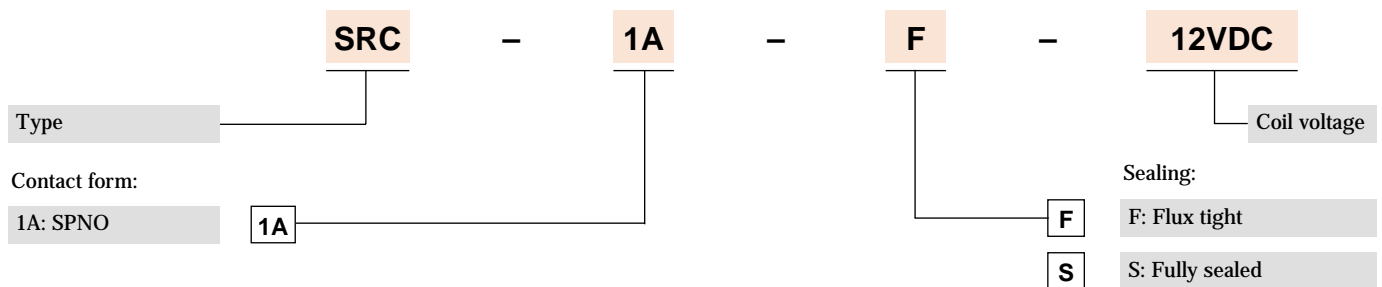

Options and ordering codes



Contact rating

Contact form	1A (SPNO)
Maximum switching power	2000VA (2400VA)* / 240W (300W)*
Maximum switching voltage	250VAC / 30VDC
Maximum switching/carry current	10A
TV rating	TV-5

UL, CSA and TUV safety approval ratings available on request.
 *Ratings for 30k ops

Specifications

Contact material	Ag SnInO	
Initial contact resistance	100mΩ Max	
Operate time	10ms Max. (at rated voltage)	
Release time	5ms Max. (at rated voltage)	
Nominal operating power	Approx. 450mW	
Insulation resistance	100MΩ at 500VDC	
Breakdown voltage	Between coil and contacts	2500VAC (for 1 minute)
	Between open contacts	1000VAC (for 1 minute)
Vibration resistance	Operating extremes	10~50Hz, amplitude 1.0mm
	Damage limits	10~50Hz, amplitude 1.0mm
Shock resistance	Operating extremes	10G
	Damage limits	100G
Ambient temperature	-30~+60°C	
Life expectancy	Mechanical	10 x 10 ⁶ operations (frequency 18,000 operations/hour)
	Electrical (at max load)	1 x 10 ⁵ operations (frequency 1,200 operations/hour)
Weight	6g	

Coil specification

Rated voltage	Rated Current \pm 10% at 25°C (mA)	Coil Resistance \pm 10% at 25°C (Ω)	Max. continuous voltage at 25°C	Pick up voltage (Max) at 25°C	Drop out voltage (Min) at 25°C	Power consumption at rated load
3	150	20	130% of rated voltage	75% of rated voltage	5% of rated voltage	Approx. 450mW
5	90.9	55				
6	75	80				
9	50	180				
12	37.5	320				
18	25	720				
24	18.8	1280				

Dimensions mm

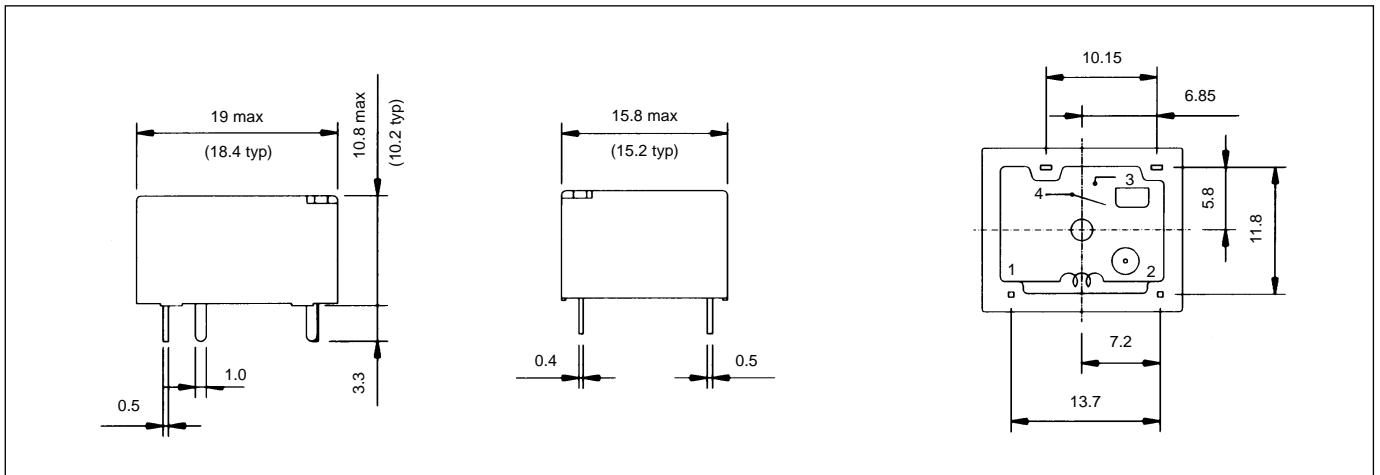

Wiring diagram

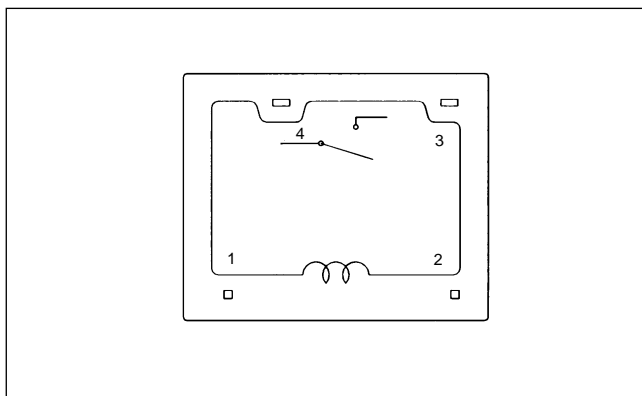

PCB layout

